

THE TRANSVERSE DIKE SPILLWAY NO. 3 FAILURE - An Investigation into the Failure Mechanism

EMILIO M. MORALES, MSCE ^{1]}

Chairman, PICE and ASEP Geotechnical Division

SYNOPSIS: A portion of the transverse Dike Spillway No. 3 was breached on August 3, 1996. The failure resulted in a break of about 67 meters of this Spillway, which is one of the 3 Spillways in the Transverse Dike of the Megadike System for the Pasig Potrero River. The Mega Dike System is an emergency dike designed to control the flow of Lahar into outlying towns and the capital city of San Fernando, Pampanga. Many theories and scholarly studies on the cause/s of failure have been brought forward as a consequence of this accident. This paper is a result of an investigation conducted by the author based on an ocular inspection of the site days after the incident, studies of photographs and field reports and conduct of various Engineering analyses in order to determine the probable cause of failure.

1.0 INTRODUCTION

Within a week after the breaching of Spillway No. 3 of the Transverse Dike in Pampanga, the author visited the site to investigate firsthand what caused the breaching from a Forensic Engineering point of view. Several other corroborating photographs were also obtained from various sources as well as data from various references.

This paper attempts to study the failure mechanism based on a broader study and engineering analyses in order to identify the specific and most likely cause of the breaching of the Spillway. No attempt has been made to pinpoint the blame on any person/s or entity. The results of the investigation are based on factual data and sound engineering principles.

In the investigation process undertaken, all possible failure mechanisms were studied resulting in the elimination of some, as not having contributed to the failure.

The study was a result of a long-term effort to gather information from various sources as well as the study of post failure evidence, mainly from engineering analyses, photographs of the relic structures and the debris. Engineering Calculations were performed to verify

adequacy of the Transverse Dike structure as designed when subjected to the flood level encountered at failure.

2.0 BACKGROUND

The Transverse Dike system is a concrete faced embankment dike structure constructed perpendicular to the East and West Lateral Dikes of the Mega Dike System designed to control the flow of Lahar along the Pasig-Potrero River system.

The Mega Dike system, of which the Transverse Dike is a component, is an emergency structure to block the massive inflow of Lahar along the Pasig Potrero River estimated to be about 50M cu.m. The purpose of the Lateral Dikes is to prevent the spread of Lahar to the cities of Angeles and San Fernando and the towns of Bacolor, Guagua and Sto. Tomas.

The Transverse Dike system was designed to control massive flood flows and Lahar by creating a sedimentation basin formed by the East and West Lateral Dikes with the Transverse Dike serving as closure.

^{1]} Emilio M. Morales MSCE - Master of Science in Civil Engineering, Carnegie Mellon University, Pittsburgh, PA, USA, Doctoral Student, Asian Institute of Technology, Chairman, PICE and ASEP Geotechnical Committees, Principal EM²A Partners & Co., Formerly Senior lecturer in Soil Mechanics and Foundation Engineering, Graduate Division, School of Civil Engineering, University of the Philippines, Chairman joint PICE/ASEP investigation team for Cherry Hills Landslide.

The Transverse Dike serves several purposes:

- Contain Lahar sediments
- Reduce the volume of water and Lahar flows downstream of the Transverse Dike
- Reduce the velocity of flood waters

Three (3) Spillway Structures (Spillway 1, 2 & 3) were provided for the Transverse Dike of identical design. However, several contractors and subcontractors were involved at one time or another in the construction of the Spillways and the Transverse Dike in general.

(1) Technical Description of the Transverse Dike:

- Length (East-West) - approx. 3 kms.
- Base width - 41 meters
- Crest width - 4 meters
- Spillway height - 9 meters
- Downstream Apron - 15 meters

The Upstream and Downstream faces were protected with an R.C. facing 150mm and 250mm thick respectively. The R.C. Apron is provided with a 2.6 meter and 1.0 meter concrete vertical face intended as a seepage barrier.

The Spillways were provided with 3 rows of Drain Pipes arranged in 7 columns. The original design called for steel pipes for all the 3 rows. However, during construction, the lowest row was substituted by large diameter R.C. Pipes. This decision became a critical factor in the investigation.

(2) The Spillway Failure Event

At around 1:00 p.m. of August 3, 1996, failure of the Dike System occurred. By 3:00 p.m. a 67 meter portion of the Transverse Dike had been washed out, totally, removing pipe columns 2, 3 & 4 and leaving column 1 on the West and columns 5, 6 & 7 to the East.

It was reported that the failure was preceded on August 1, 1996 by an earthquake of Magnitude 5.8. No damage was reported immediately after the earthquake or on August 2, 1996.

Eyewitness accounts immediately prior to the breaching of the Transverse Dike indicated that leaks started appearing in the concrete armor facing followed by sudden upward tilting of the pipes and progressive failure within 2 hours. A study of the site by the Author, and as recorded in photographs generally concurred with eyewitness accounts as R.C. pipes which were left, were tilted upward at the outlet end and downwards inside the dike core

What caused the failure?

This paper seeks to unravel the mystery and in the process identify the failure mechanism based on investigation of all possible scenarios that could cause the failure or contribute to such failure.

(3) Investigative Study

This study got started almost within a week from the failure as the author visited the site to inspect the failure debris and study the remnant or relic structures that were left after the breaching. This included going inside the cavernous void inside the remnant of the dike where the pipes were located. Discussions at site during the inspection were made with various DPWH personnel as well as locals who were spectators to the incident.

Photos were also taken or obtained from various sources during the course of the investigation leading to this report.

As earlier indicated, the investigation covered all major possible cause/s for failure namely:

- Design
 - Seepage
 - Piping
 - Slope Stability
 - Structural adequacy of Downstream RC Facing
- Construction Details and Quality
 - Ocular Site inspection at time of incident
 - Inspection of RC Pipe Construction Details
 - Inspection of Dike RC Facing
 - Study of DPWH Plans

These were aided by information gathered, more particularly photographs, taken at the failure site after the breaching. These photographs served as important pieces of the puzzle in the Engineering Investigation and study conducted.

3.0 INVESTIGATION OF DESIGN

The investigation and Engineering analyses conducted were based on the plans and details of the spillway dike. The analyses procedures were done in accordance with standard engineering practice in the investigation of failures. In addition, parallel computational procedures were used whenever possible in order to check on the results, particularly in the very critical analysis of seepage effects.

The Engineering analyses were conducted on the following critical aspects of the Investigation of the design in the order of importance as relates to the Failure analysis:

- Seepage Analysis using conventional Flownets and Finite Element analysis using SEEP2D Software.
- Piping analysis by evaluation of the Critical Gradient (i_{crit}) and Average Gradient (i_{ave}) at the Toe of the Dike Structure.
- Slope Stability Analysis using SLOPE/W Finite Element Analysis software.
- Structural Analysis of the RC Downstream Facing using STAAD Software.

All of the foregoing Computer Softwares used are universally accepted software commonly used by the Engineering profession. The results and input codes may be obtained from the author upon request.

(1) DESIGN PARAMETERS USED IN THE DESIGN INVESTIGATION

In the investigation of the design, the design parameters used were gathered independent of the design done by others. The parameters selected, particularly the soil properties used in the seepage analysis and Dike stability analysis were obtained from literature and various references.

As in any Failure investigation, the Analyses Parameters selected tended to be on the low side, in order to be conservative in the investigative results.

The table below summarizes the physical properties of materials used in this study.

Table 1.0 - Assumed Soil Properties

Material	Type	ϕ	γ_s	G	e	K cm/sec
Dike Material	Compacted Lahar	34	118	2.65	0.50	1.5×10^{-4}
Dike Foundation	Natural Deposition	31	110	2.65	0.60	1.5×10^{-3}

- ϕ = phi angle in degrees
- γ_s = unit weight of soil
- G = specific gravity of lahar materials
- e = voids ratio
- k = coefficient of permeability in cms/sec

To simplify the seepage analyses, the foundation material was considered to be fairly homogeneous down to the depth of interest for the seepage and stability analyses. Again, this would be on the conservative side as the density of underlying lahar sands at site were generally increasing with depth.

(2) SEEPAGE ANALYSIS

The seepage analyses were conducted using the universally accepted conventional *Flownet Analysis*²¹, which is a graphical presentation of flux or flow of a liquid or an electrical current in a field from a region of higher potential to a region of lower potential.

In turn, a 2D Finite Element Analysis using *SEEP2D* Seepage analysis software and its Graphical Pre and Post processor *FASTSEEP* were used to verify the results of the Flownet Analysis.

The figures below represent the Flownet and Finite Element computer analysis of the seepage condition at the time of failure when the floodwaters rose to 5.5 meters or about 3.5 meters from the Spillway Crest.

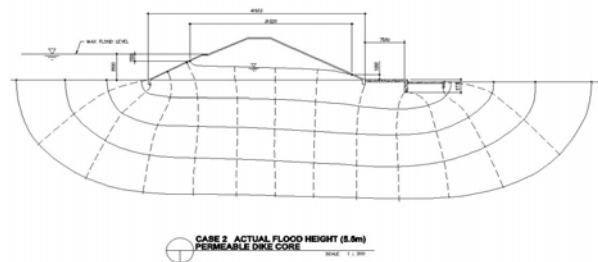

Fig 1.0 - Flownet Analysis of Transverse Dike

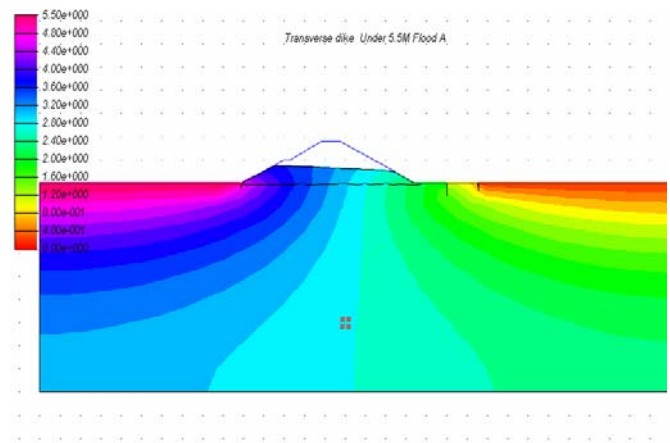

Fig 2.0 Finite Element Analysis using SEEP2D

²¹ A 2D Finite Element Seepage Computer program developed at Brigham Young University, Provo, UTAH.

The above figures show striking similarity and agreement with each other and generally confirm correctness of the results of the two independent analytical procedures. The results clearly indicate that no detrimental seepage pressures could result from the floodwaters rising to 5.5 meters nor could harmful heave forces be generated underneath the base of the transverse Dike spillway structure.

A closer study of the flow diagrams in both figures show a hydrodynamic lag in the rise of the phreatic surface inside the Dike core as a result of the upstream concrete facing serving as an impermeable blanket or barrier. This was generally anticipated and the seepage analyses results show the positive effect of the upstream and downstream RC Facing or Blanket.

From this, it was also possible to calculate the resulting hydrostatic pressure on the downstream facing for analysis of its structural adequacy.

An analysis of the heave pressures developed at the base of the Spillway Dike, as the floodwaters rose, was also performed to determine whether heaving of the Dike core was likely.

The results of the calculations (included in *Appendix "A"*) indicate that the dike design would be adequate to sustain the seepage forces as well as heave at time of failure.

(3) PIPING ANALYSIS

Piping is a physical phenomenon, which results in a "quick" condition; terms normally used to describe a "quick" condition are "sandboil" and "quicksand".

Piping occurs when the buoyed unit weight of the soil γ_s' is less than or equal to the seepage force acting in an upward direction. As a consequence, the effective stress becomes zero and the soil is floated and disaggregated resulting in a "liquefaction" effect.

Normally, piping occurs at the downstream toe of the Dike or Dike system when the exit gradient is relatively high and where the total weight of the soil column resisting the seepage force is at a minimum compared elsewhere in the Dike section. The piping then progresses inward to cause a tunneling effect, which can undermine the stability of a dike or a dam.

Piping can also occur within a dam base, particularly when the seepage velocity is relatively high or in the

presence of highly permeable gravel formations as to carry fine particles downstream. However, and as verified from the SEEP2D analyses, the seepage velocities were very low due to the relatively low permeability of the Lahar sands (classified as Silty sand) and Borings did not indicate any gravel formation of any significance to the study.

At the critical liquefaction state, this condition is expressed in the following soil mechanics phase relations equation:

$$i = \frac{\gamma_s - \gamma_w}{\gamma_w} = \frac{\gamma_s'}{\gamma_w} \quad (1)$$

Where:

- i = is the hydraulic gradient
- γ_s = unit weight of soil
- γ_w = unit weight of water
- γ_s' = $(\gamma_s - \gamma_w)$ buoyed unit weight of soil

When $i > 1.0$, liquefaction or piping will not occur.

When $i < 1.0$, piping can occur given the right conditions.

Thus, for this condition, the resulting gradient is defined as the critical Hydraulic Gradient i_{crit} .

From phase relationship of soils:

$$\gamma_s' = \left(\frac{G_s - 1}{1 + e} \right) \gamma_w \quad (2)$$

where:

- G_s = specific gravity
- e = voids ratio
- γ_s', γ_w = as defined above

Therefore, substituting in equation (1):

$$\frac{\gamma_s'}{\gamma_w} = i_{crit} = \left(\frac{G_s - 1}{1 + e} \right) \quad (3)$$

Thus:

$$i_{crit} = \left(\frac{G_s - 1}{1 + e} \right) \quad (4)$$

In the design of hydraulic structures, it is very important to ensure that the critical hydraulic gradient i_{crit} is not reached through careful selection of materials (to obtain higher Specific gravity of the soil G_s and/or compaction in order to decrease the voids ratio e).

Using the foregoing assumed soil properties in Table 1.0 we determine the critical hydraulic gradient as:

$$i_{crit} = \left(\frac{2.65 - 1}{1 + 0.60} \right) = \frac{1.65}{1.60} = 1.031 > 1.0 \quad \text{OK} \quad (5)$$

Thus, the value of i_{crit} is greater than 1.0 and is thus acceptable.

To further determine the factor of safety against piping it would be necessary to obtain the seepage forces acting upward against an element of soil at the downstream toe from the flownet of Fig. 1.0.

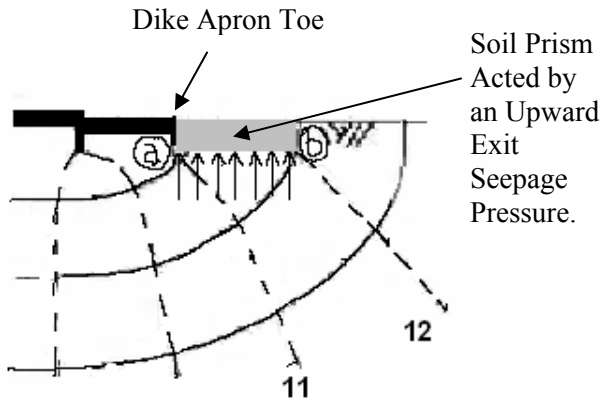

Fig 3.0 - Portion of Flownet at Downstream Exit Point

Between the equipotential drops $N_D=11$ and $N_D=12$, the heads are (see Appendix "A").

$$N_{11} = 0.846\text{m}$$

$$N_{12} = 0.423\text{m}$$

The distance a-b is 7.0m (scaled)

Thus;

$$h_{ave(a-b)} = \frac{0.846 + 0.423}{2} = 0.6345 \quad (6)$$

The hydraulic gradient acting upward against the soil element 7.0 meters wide is;

$$i_{ave} = \frac{0.6345}{7.0\text{m}} = 0.091 \quad (7)$$

The factor of safety against piping is;

$$F.S. = \frac{i_{crit}}{i_{ave}} = \frac{1.031}{0.091} = 11.32 \quad \text{OK} \quad (8)$$

From the above, it can be shown that the Dike structure is safe against piping.

(4) STRUCTURAL INVESTIGATION OF D.S. RC FACING

The only other possible cause of the breaching from a Design point of view, is if the downstream armor facing failed due to hydrostatic pressure build-up inside the core as a result of rise in the phreatic surface. Such damage could allow fines to be washed out through the facing and thus internally collapse the dam. For the given flood condition, this can only occur at the bottom 3 meters of the downstream facing.

At the flood condition of 5.5m, the resulting phreatic table elevation at the back of the downstream facing is about 2.31m as computed from the SEEP2D Finite Element Analysis.

The downstream reinforced concrete facing is a 250mm thick concrete mat reinforced both ways by 12mm ϕ rebars at 300mm o.c. both ways.

In order to determine the force at the back of the downstream facing, the following condition was modeled using the portion of the RC Facing subjected to Hydrostatic pressure as a 5.27 meter square plate fixed or fully restrained at all edges or a plate that is pinned on all sides:

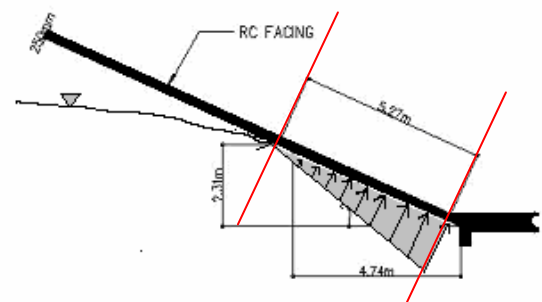

Fig 4.0 - Pressure Diagram at DS RC Facing due to Rise in Phreatic Surface in Dike Core

These two support conditions represent the upper and lower extremes insofar as support condition is concerned. The assumption of a 5.27m span is a very conservative assumption since probably a shorter slab span would be more realistic. The slab was analyzed as a flat plate acted on by a triangularly varying load. The condition of fully restrained (*fixed*) and Pinned conditions were used on a 5.27m square plate dimension.

The results are as follows:

$M_{Capacity}$	=	11.42 kN-m
M_{Fixed}	=	6.21 kN-m (Very Safe)
M_{Pinned}	=	13.80 kN-m (20% over)

Thus, it can be seen that even at the Pinned condition, the facing is only 20% overstressed and is very safe using a full Fixed condition.

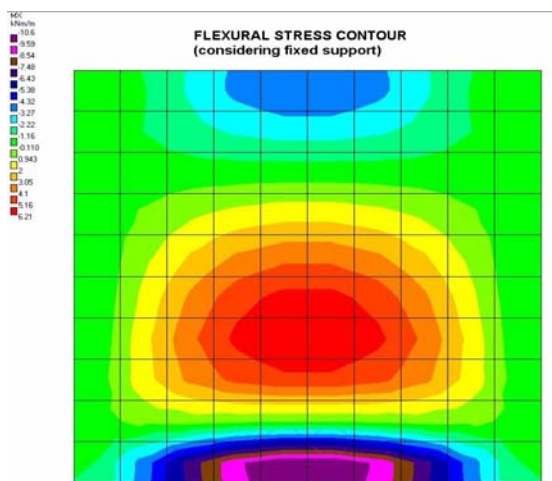

Fig 5.0 - Stress Contours of Downstream Facing Slab Subjected to Internal Water Pressure due to Rise in Phreatic Surface (Fixed Ends)

The truly realistic condition would be somewhere in between these two support conditions that would render the facing safe for the flood condition, not to mention the very conservative large slab span assumed.

From the foregoing, we can conclude that the R.C. facing did not fail from the hydrostatic pressure developed inside the Dike Core.

(5) SLOPE STABILITY ANALYSIS

A two-dimensional slope stability analysis of the Dike core was performed using SLOPE/W, one of the more

popular slope stability analyses program used worldwide by Geotechnical Engineers.

The results were obtained from analyses of the Dike stability both at failure condition (5.5m) and due to earthquake.

The slope stability analysis results indicated that the Dike is safe at static condition with a Factor of Safety (FS) equal to **1.279**.

Earthquake loading was considered in the analysis corresponding to a 5.8 Magnitude Earthquake coincident with the flood level of 5.5m Flood as a purely academic exercise. The results show that the dike is marginally safe (**FS=0.989**) for combined earthquake and flood level of 5.5 meters, which is an unlikely combination.

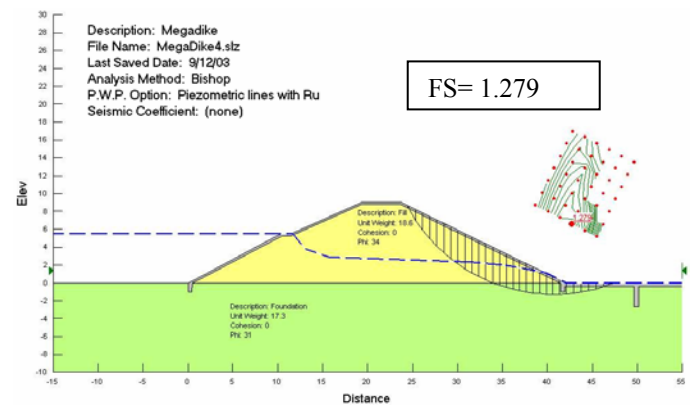

Fig 6.0 - Result of Slope Stability Analysis using SLOPE/W at Static Condition

(6) HEAVE ANALYSIS

From the Flownet analysis, the equipotential lines intersecting the base of the dike are converted to upward pressure. This pressure tends to heave the dike and is only counteracted by the weight of the Dike Structure.

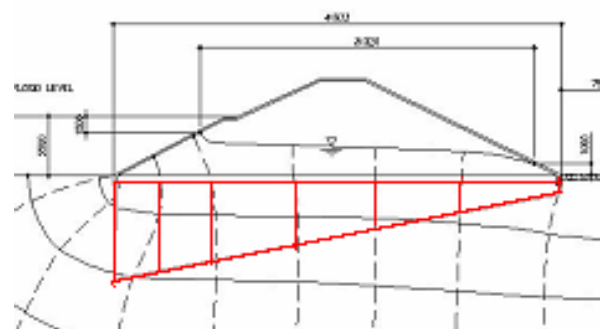

Fig 7.0 - Pore Pressure Distribution at Base of Dike due to 5.5m Flood Height

The analysis and results are shown below:

W_d = Weight of Dike = 873.66 kips

P_{SP} Total upward Force at Base = 297.7 kips

$$F.S. = \frac{W_d}{P_{SP}} = \frac{873.66}{297.70} = 2.93 \quad \text{Safe} \quad (9)$$

(7) SUMMARY OF FINDINGS IN THE INVESTIGATION OF THE DIKE DESIGN

From the foregoing, we can summarize the findings resulting from the investigation of the Design as follows:

- **Seepage Analysis** - **Safe**
 - F.S. against Piping - 11.32 very adequate
 - F.S. against Heave - 2.93
- **Dike Stability (Slope Stability)**
 - F.S. Static Condition - 1.279 adequate
 - F.S. Seismic Condition - 0.989 OK (see Discussion)
- **Slope R.C. Facing DS**
 - R.C. Facing Slab structurally adequate against build-up of hydrostatic pressure for Flood level Failure.

Thus, it can be concluded that the Dike design was adequate for the Conditions at the time of failure.

4.0 INVESTIGATION OF CONSTRUCTION DETAILS

The author considers that the best way to present the bases for this portion of the investigation is to present these in photographs taken after the failure, coupled with corresponding observations and commentaries of the author based on his ocular inspection at site and reviews of various reports.

From these, and by elimination, conclusions can be formed as to whether any of the feature/s have contributed or not to the Failure in the same way that the Investigation of the design was carried out in the first part of this paper.

(1) BACKGROUND

The original construction called for the installation of 3 rows of relief pipes in 7 columns for each of the 3

Spillways.

These relief pipes were designed to allow water and lahar in suspension to be drained to reduce buildup of hydrostatic pressure at the upstream side during normal flows. Eventually each layer of pipe will be naturally deactivated by the buildup of sediment at the upstream side, effectively blocking the flow. These pipes were originally specified to be all steel pipes.

Sometime during construction, a field change was made by substituting large diameter R.C. Pipes at the bottom row for the steel pipes originally specified as the specified diameter steel pipes were not readily available in the market. This change was implemented in the final construction.

Prior to the failure, it was reported that all the R.C. pipes in the lowermost row stopped flowing. Eyewitness accounts gathered from various reports indicated that although at the downstream end the flow was completely stopped, there was rapid intake forming a whirlpool at the upstream pipe intake, followed by cracking of the downstream R.C. Facing and seepage coming out through the cracks and eventually by massive collapse.

Photographs taken at the site corroborate these observations.

The picture below shows what remained of the spillway after a 67 meter section was breached. A closer look at this photo, looking West, shows that the Dike core was internally eroded with the Downstream and upstream armor RC facing collapsing into the core.

The subsequent photos will explain why and how this happened.



Photo A

(2) R.C. PIPES

The R.C. Pipes are 900 mm Ø x 1.0 meter long. These were designed to be bedded or laid on a Reinforced Concrete Bedding in turn resting on a well compacted subgrade composed of dike core materials shown in the revised project plans and sketched here below as Fig. 8.0.

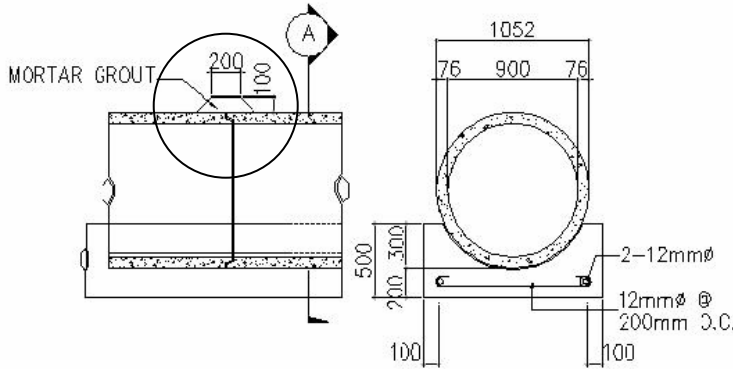

Fig 8.0 Detail of Pipe RC Bedding as per Plan

The detail above shows that the bedding concrete is to be reinforced by 2-16 mm φ Longitudinal rebars and 12 mm φ transverse ties at 200 mm on centers.

Also, the dimensions of the pipe Mortar Grout are shown to be 200 mm wide and 100 mm thick tapering at the ends.

The subsequent photographs show critical deviations from the above requirements as contained in the plans as follows:



Photo No 1

Photo No 1 clearly shows the absence of rebars on the bedding concrete. The bedding has completely sheared off at the joint allowing massive inflows inside the Dike Core creating the massive caverns shown in the subsequent photos. Note that the mortar grout had been removed at one side.



Photo No 2

Photo No 2 also shows the same absence of rebars in the supposed to be reinforced Concrete bedding. As can be noted, most of the pipe breakages were at the critical pipe joints where the pipe is weakest. However, total collapse and full breakage of the pipe joints could have been prevented or minimized if the concrete bedding reinforcement had been placed in accordance with the plans and details.....



Photo No 3

Photo No 3 shows that the Mortar grout that was placed when compared to the scale of the pipe indicates that the mortar grout dimensions specified in the plans were not followed. Also, note that the thickness of the Mortar grout at the top of the pipe is very much

different only at a short distance away from the top along the sides. Why this is so is not clear to this investigator.

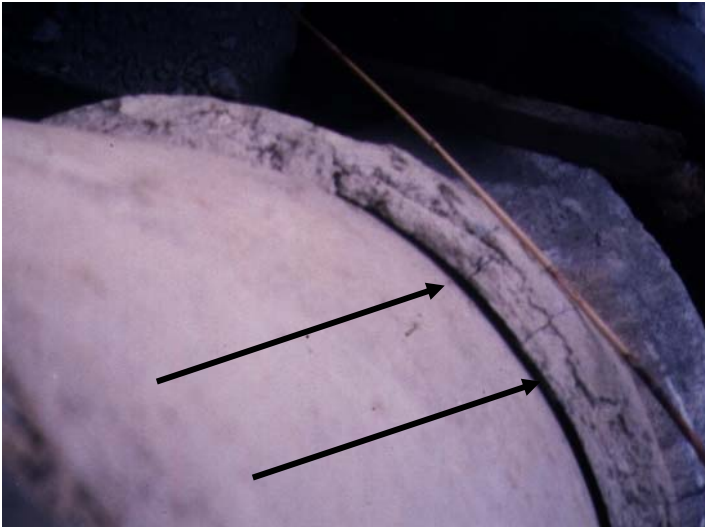

Photo No 4



Photo No 5

These photographs (Nos 4 & 5) show the poor quality of the mortar grout. Note the gap that was neatly debonded from the pipe body in Photo No 4. Although not clearly discernible in this photo, the mortar grout is relatively less than the 100 mm thickness specified in the plans.

Photo No 5 more clearly illustrates the quality of the Mortar grout as laid and its actual thickness.



Photo No 6

This photo No 6 shows the pipes tilted upward as it daylights at the outlet end downstream. The armor facing has collapsed inward. Also to be noted in this photo is the cavity formed underneath the facing and alongside the pipes.

The pipe tilted inward indicates that internal collapse occurred rather than an outward failure that could have been caused by excessive build-up of pressure inside the dike core otherwise, the pipes could have been pushed downward and out.

This clearly suggests that undermining from internal erosion caused by Internal leaks along the pipe joints was the most probable cause. These leaks which became critical as the leaks progressively got bigger eventually led to the critical breakage of the unreinforced concrete bedding at the pipe joints causing massive pressurized flows inside the dike core.

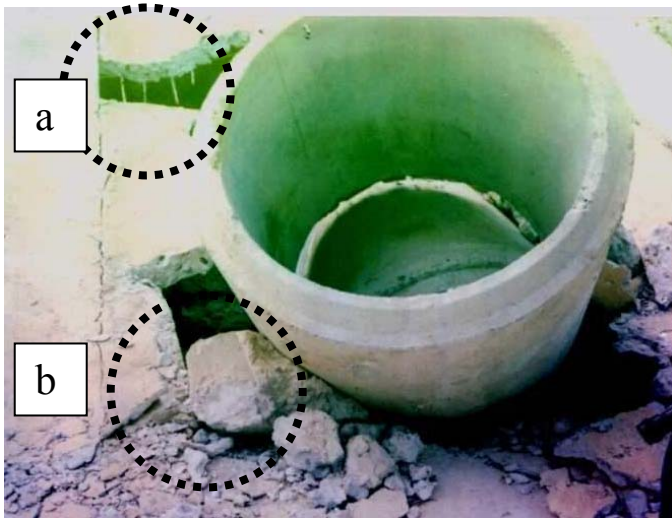

Photo No 7

This photo No 7 shows the pipes also tilted upward at the outlet end downstream as in previous photo No 5. The pipe inside also shows undermining of support more clearly visible in the previous Photos (Photo No 3 & 6) above.

Note the cavity in the background (Inset “a”) and the location of the rebar of the armor facing relative to the facing thickness. Inset “b” also again shows the absence of rebars in a remnant of the bedding concrete that is still partially attached to the RC pipe.

All of the foregoing photographs show significant deviation from the plans and/or good construction practice in three critical requirements:

- Lack of longitudinal and transverse reinforcing bars for the RC Bedding.
- Inadequately sized mortar joint details
- Poor Quality of Construction

The foregoing deviations clearly have a significant role to play in the failure that ensued. It is only a matter of tying the pieces together to establish the Failure mechanism that caused the breaching of the Spillway No 3 of the Transverse Dike.

(3) DOWNSTREAM RC ARMOR FACING

The second element of the dike to be investigated was the Reinforced concrete armor Facing at the downstream side.

The plans and details of the transverse Spillway Dike called for a 250 mm thick RC Facing reinforced by 12 mm ϕ rebars at 300 mm on centers both ways. The details show that the rebars are to be placed at the middle of the RC Facing thickness.

The following photographs show evidence that the rebar placement was different from that specified in the plans.



Photo No 8

Photo No 8 show the rebars as laid out in the actual construction. The rebars are all at the bottom or nearly at the bottom of the RC Facing where it is ineffective in resisting lateral forces from internal water pressure. Our structural analyses indicated (See section 4 pages 5-6) that if the rebars have been correctly placed in the middle, the facing slab would have been adequate to sustain the lateral pressure buildup due to the rise in the phreatic surface inside the dike core. No analysis is required to show that the facing concrete would fail once the tensile capacity of the Concrete (which is very minimal) is reached. This explains the disintegration of the concrete facing as can be seen in Photo A.



Photo No 9

This photo shows the rebars debonded from the RC Facing . The picture also show that the rebars were not placed in the middle of the Facing but rather at the bottom portion of the slab where it is ineffective in “reinforcing” the concrete facing.

The wrong placement of rebars is also seen clearly in Photo No 7.

(4) SUMMARY OF FINDINGS ON CONSTRUCTION DETAILS

The foregoing photographs (Photo 1 to 9) established the following major deviations from the plans:

1. The Mortar grout dimensions and quality did not comply with the plans and standards of construction.
2. The RC Bedding did not have any reinforcement at all.

3. The RC Facing at the downstream side of the dike had the rebars laid at the bottom of very near bottom of the Facing slab where it was ineffective in resisting outward pressures from the build-up in the phreatic surface within the core of the dike.

These significant departures from the plans and quality standards have a role to play in the Failure mechanism that could be pieced together from the failure event as well as the study of the remnant or relic structures and failure debris.

Taken individually, the following are the contributions to the Failure mechanism:

1. The inadequate mortar grouts allowed leaks at the joints causing progressive erosion and cavitations within the Dike core.
2. The unreinforced pipe bedding gave way by completely shearing at the joint as the subgrade support is eroded by leaks. This in turn caused a major pipe breakage stopping the flow completely at the outfall end (*as observed by eyewitnesses immediately prior to failure*) and discharging the full pipe flow within the dike core. This in turn increased the hydrostatic head within the dike core to the available head at the upstream (5.5 m). The pressure build-up induced lateral pressure on the RC Facing. The pipe breakage caused the full discharge of the pipes under a 5.5 m head to internally erode the dike core causing further breakages in other pipes and forming huge cavities inside.
3. The wrong placement of the rebars (Nearly at the Bottom of Facing) gave the facing very minimal flexural resistance against the outward lateral pressure build-up causing failure of the concrete in tension and in places completely debonding the reinforcement from the concrete slab. This explains the breakup of the facing into small slab panels as shown below (see also Photo “A”):



It is possible, although there is no proof to substantiate this, that the Earthquake of August 1, 1996 caused the initial dislodgement of the RC pipes or debonding of the poorly constructed joints as to trigger the initial leakage which became a massive flow when the pipes sheared at the joints.

However, even without such disturbance, leaks are likely to occur in the poorly constructed joints and weak bedding support, that could lead to similar failures as has occurred.

Thus, the likely failure mechanism is as described above. This is supported in turn by several other observations as described below:

- The RC pipes at the outfall ends were tilted upward suggesting internal collapse.
- The RC Facing slabs have dished in inward suggesting internal collapse of the Dike core.

4.0 CONCLUSIONS

The results of the Engineering investigation as supported by engineering analyses and calculations, indicate that the Transverse Dike Spillway design was adequate for the conditions encountered at failure and that no detrimental seepage condition could likely form as to cause failure. The possibility of collapse due to Piping also can be ruled out. The Engineering analysis of the piping at the downstream end indicates that the critical Gradient is adequate and cannot be overcome by the upward seepage gradient.

The same cannot be said of the construction details as uncovered during this investigation from ocular observations done by the author, from photographs taken after the failure and from corroborative eyewitness accounts as documented in various reports.

The Transverse dike failure can only be directly attributed to internal erosion within the dike core, which could have only been caused, initially by a leak or leaks in the pipe joints followed by massive discharge after the leaks have undermined the pipe supports, causing the pipes to fail at the joints. This conclusion is backed up by corroborative description of what happened immediately before the failure as contained in various investigation reports and also by the photographs contained in this paper.

5.0 LESSONS LEARNED

The engineering profession and the Construction Industry can learn a lot from such investigations of failures. It allows us to look back at our mistakes so that they would not be repeated in the future. In addition careful attention to seemingly unimportant details in normal construction become critically important when used for other more critical structures.

- Clear departure from the plans by the omission of rebars in the bedding concrete could have been easily detected during construction, with adequate quality control and supervision.
- A case in point is the mortar grout for RC Pipes. Whereas minor leaks do not become evident or are tolerable in drainage pipes which are normally not flowing full or not under full head, such leaks within a 9.0-meter earthen dike embankment could really be disastrous as proven by this incident.
- The absence of care in the laying of the reinforcement for RC Facing, clearly evident in this incident, should not have happened with proper care and adequate superintendence .